

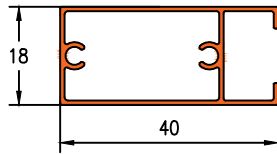

Die No. 1531 0.900 kg/12FT

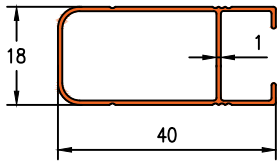

Die No.	W / 12FT
1571	0.900-1.000
1571	1.000-1.200
1571	1.200-1.400
1571	1.400-1.600
1571	1.600-1.800
1571	1.800-2.000

Die No. 1532 1.250 kg/12FT

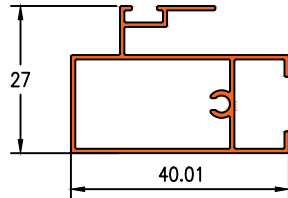
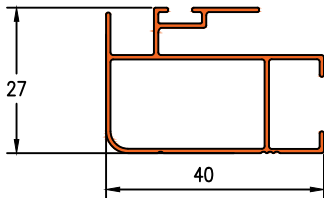

Die No.	W / 12FT
1552	1.200-1.400
1552	1.400-1.600
1552	1.600-1.800
1552	1.800-2.000

Die No. 19825 1.400 kg/12FT

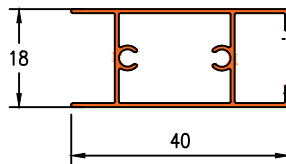
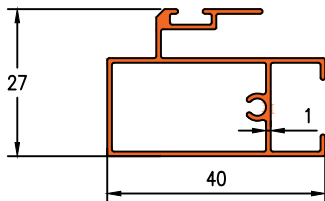

Die No.	W / 12FT
1592	0.900-1.000
1592	1.000-1.200
1592	1.200-1.400
1592	1.400-1.600
1592	1.600-1.800
1592	1.800-2.000

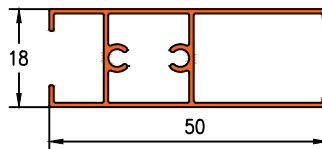
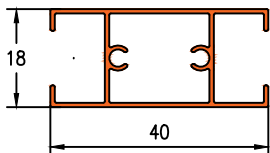

Die No.	W / 12FT
1593	1.000 - 1.200
1593	1.200 - 1.400

Die No.	W / 12FT
1631	1.000-1.200
1631	1.200-1.400
1631	1.400-1.600
1631	1.600-1.800
1631	1.800-2.000



Die No. 1528

1.500 kg/12FT

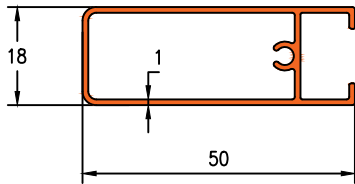

Die No. 1529

1.610 kg/12FT

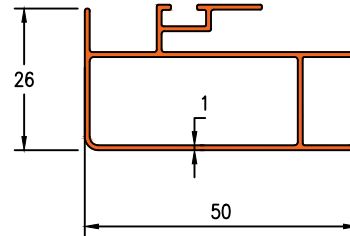

Die No. 1505

1.560 kg/12FT

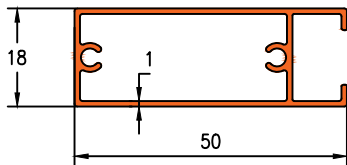

Die No. 1501

1.550 kg/12FT

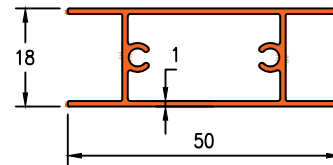

Die No. 1530

1.620 kg/12FT

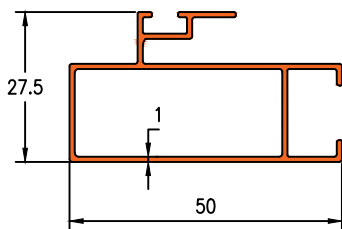

Die No. 1510

1.700 kg/12FT

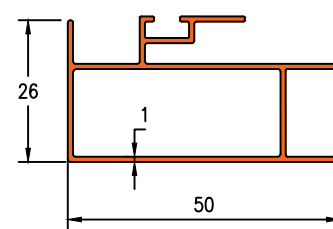

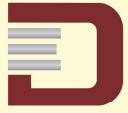

Die No. 1525

2.110 kg/12FT

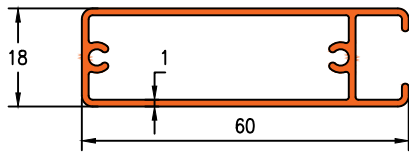

Die No. 1526

2.309 kg/12FT

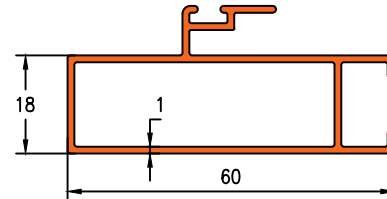

Die No. 1527

1.950 kg/12FT

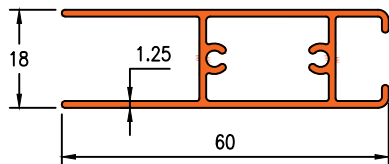

Die No. 1534

1.550 kg/12FT

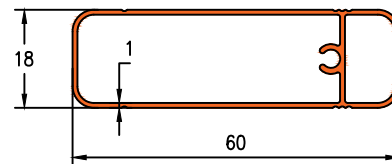

Die No. 1533

2.050 kg/12FT

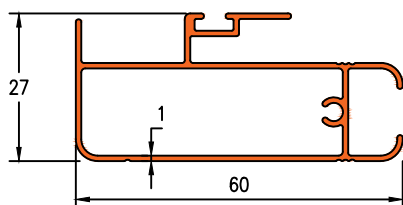

Die No. 16133

1.450 kg/12FT

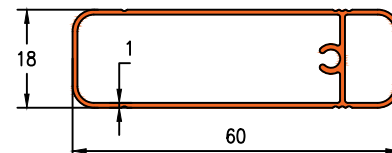

Die No. 16142

2.150 kg/12FT

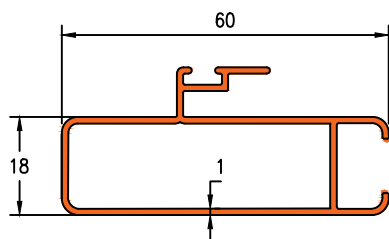



Die No. 1101

0.950 kg/12FT

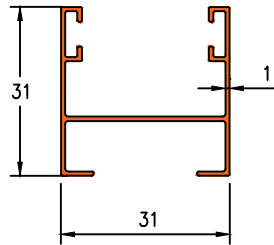

Die No. 1102

1.080 kg/12FT

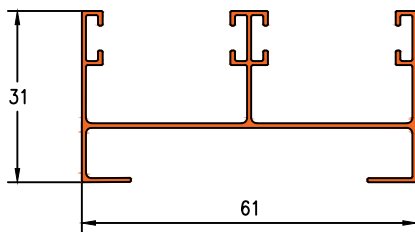
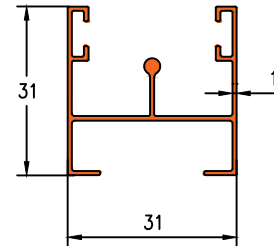

1121	1.200-1.400
1121	1.400-1.600
1121	1.600-1.800
1121	1.800-2.000

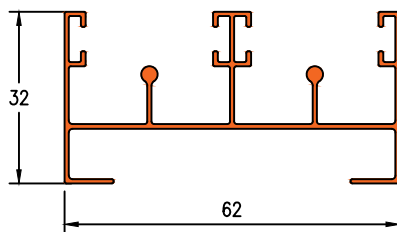

Die No.	W / 12FT
1122	1.400-1.600
1122	1.600-1.800
1122	1.800-2.000

Die No. 20015

1.400 kg/12FT

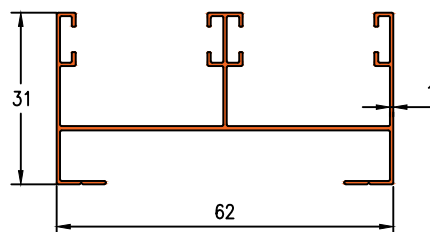

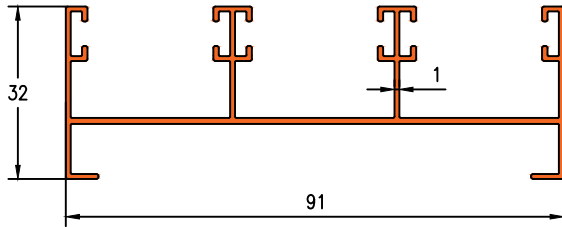

Die No.	W / 12FT
1142	1.800-2.000
1142	2.200-2.400
1142	2.400-2.600
1142	2.600-2.800
1142	2.800-3.000

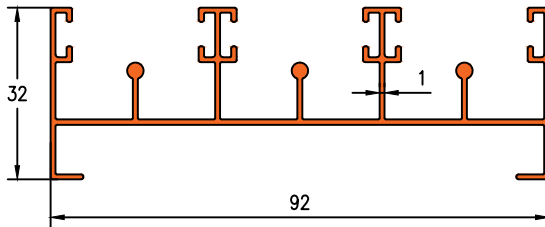

Die No.	W / 12FT
1143	1.800-2.000
1143	2.200-2.400
1143	2.400-2.600
1143	2.600-2.800
1143	2.800-3.000

Die No. 19463

2.100 kg/12FT

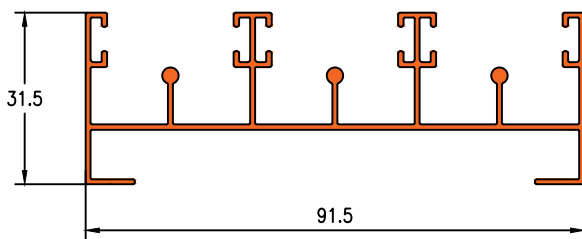

Die No. 19464

1.900 kg/12FT

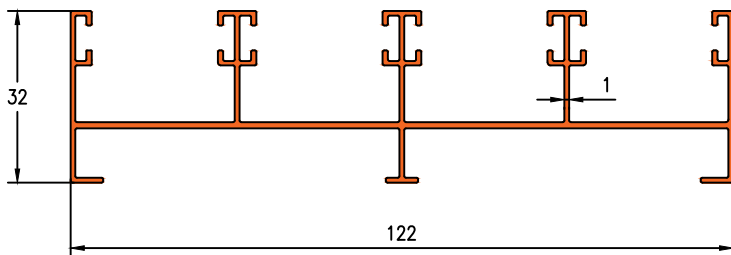
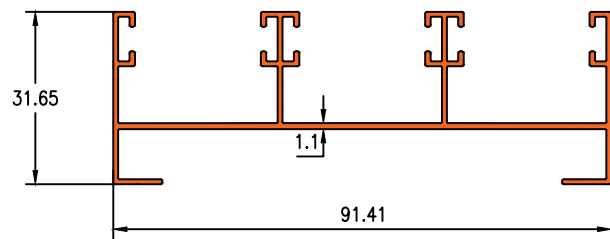

Die No.	W / 12FT
1150	2.800 - 3.000
1150	3.000 - 3.300
1150	3.300 - 3.600
1150	3.600 - 4.000



Die No. 1162

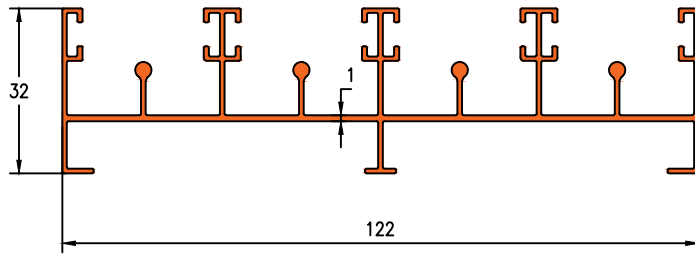

Die No.	W / 12FT
1162	3.300 - 3.600
1162	3.600 - 4.000
1162	4.500 - 5.000
1162	6.000 - 6.500

Die No. 1167

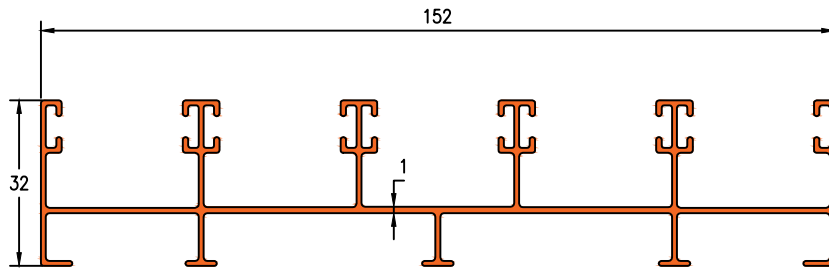

Die No.	W / 12FT
1167	3.600 - 4.000
1167	4.000 - 4.500
1167	5.000 - 5.500

Die No. 1168

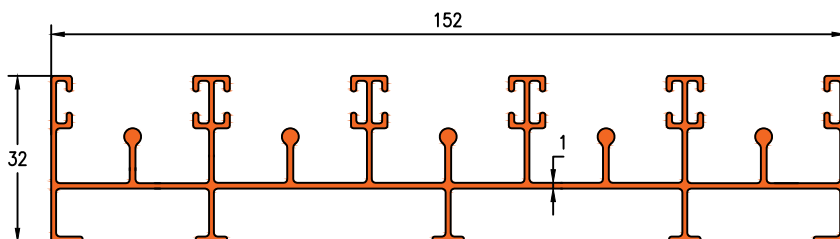

Die No.	W / 12FT
1168	4.500 - 5.000
1168	5.000 - 5.500
1168	6.000 - 6.500

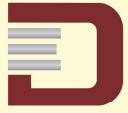

Die No. 16091

3.280 kg/12FT

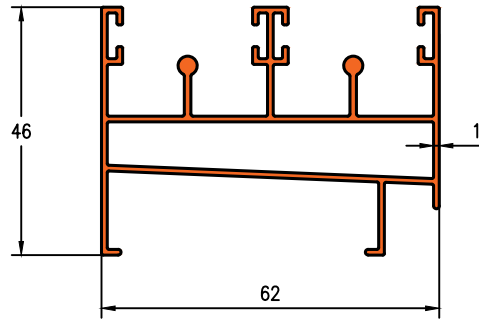

Die No. 16092

1.260 kg/12FT

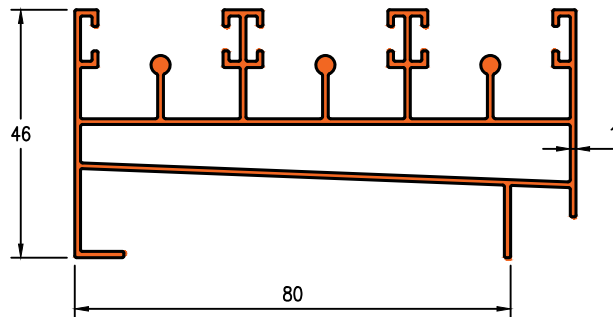

Die No. 3003

3.350 /12FT

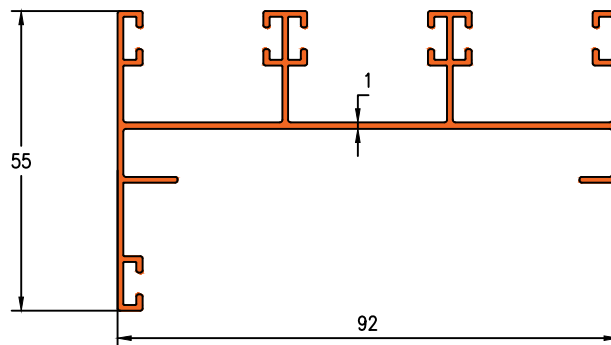

Die No. 19905

6.130 kg/12FT

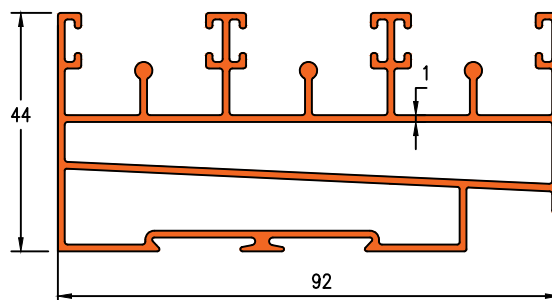



Die No. 16035

1.830 kg/12FT

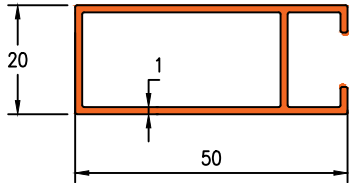

Die No. 16027

2.040 kg/12FT

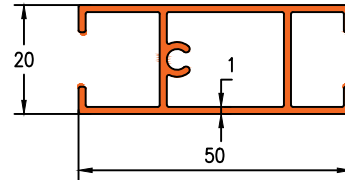

Die No. 16028

2.160 kg/12FT

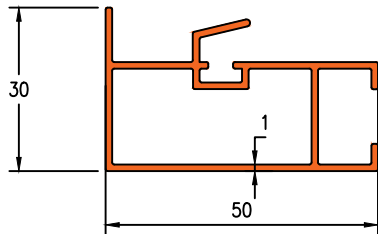

Die No. 16029

1.650 kg/12FT

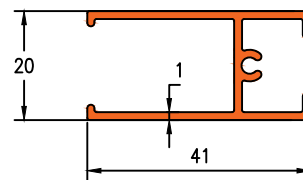

Die No. 16031

2.250 kg/12FT

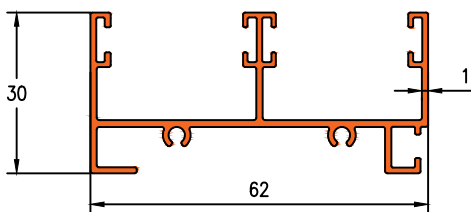

Die No. 16030

2.670 kg/12FT

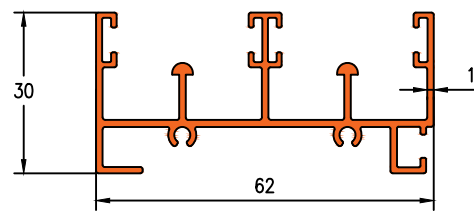

Die No. 16032

2.880 kg/12FT

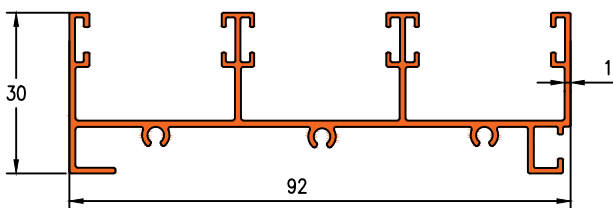

Die No. 16033

3.619 kg/12FT

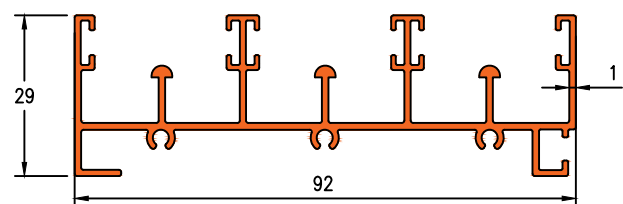

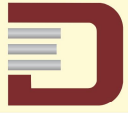

Die No. 16184

0.542Kg/m

Die No. 19552

0.563Kg/m

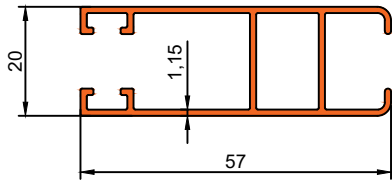

CLIP: 16182

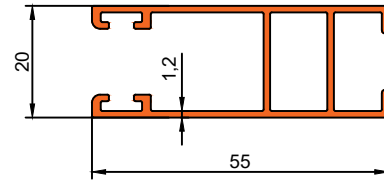

CLIP: 16182

Die No. 20032

0.429 Kg/m

Die No. 16182

0.238 Kg/m

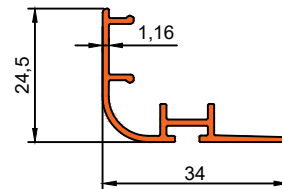
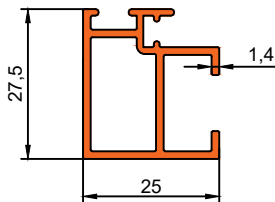

Die No. 16189

0.542Kg/m

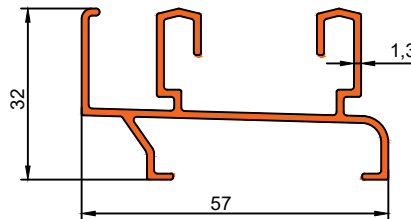

Die No. 16190

0.839Kg/m

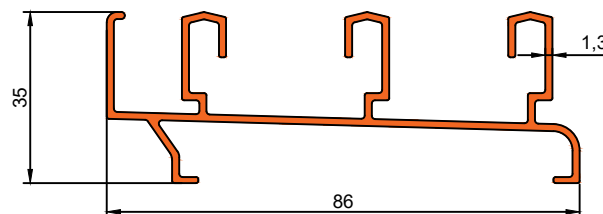



Die No. 16191

1.121Kg/m

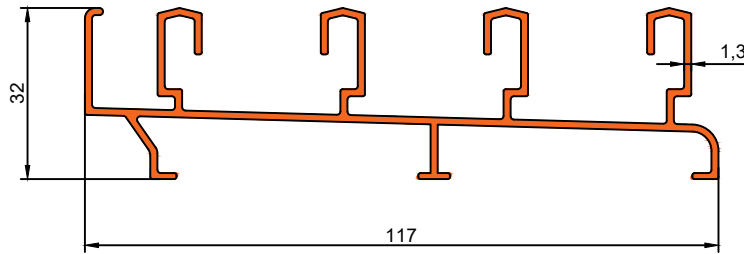

Die No. 16183

0.849Kg/m

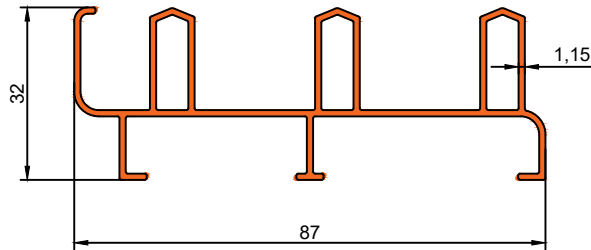



Die No. 7115

0.924Kg/m

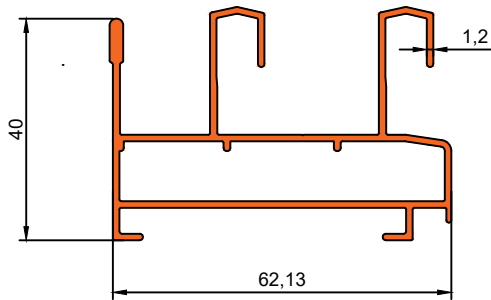

Die No. 7116

1.301Kg/m

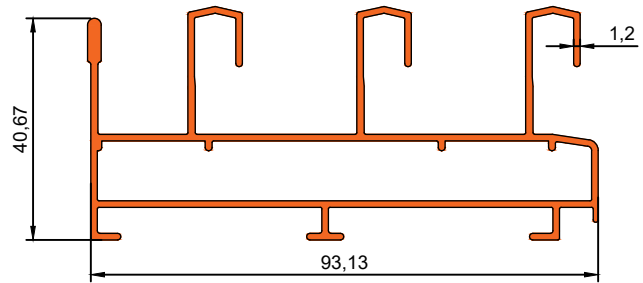

Die No. 7114

0.421 Kg/m

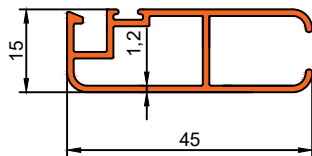

Die No. 7112

0.579Kg/m

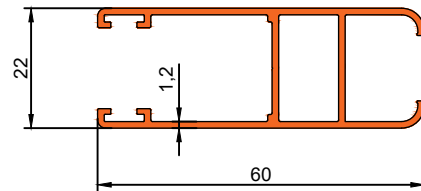

Die No. 7113

0.262 Kg/m

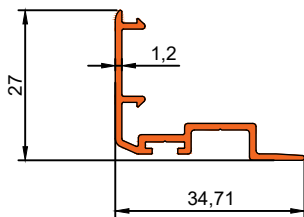

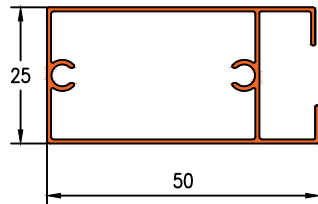
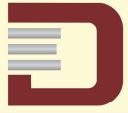

Die No.	Wt/ 12ft
1611	1.400-1.600
1611	1.600-1.800
1611	1.800-2.000
1611	2.000-2.200

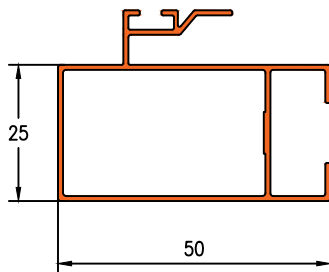

Die No.	Wt/ 12ft
1615	1.800-2.000
1615	2.000-2.200
1615	2.400-2.600

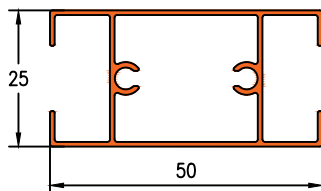

Die No.	Wt/ 12ft
1612	1.600 -1.800
1612	1.800-2.000

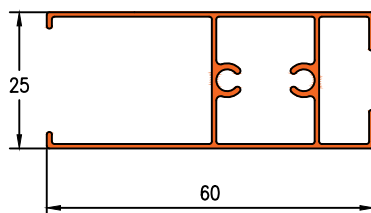

Die No.	Wt/ 12ft
1621	1.800 - 2.200
1621	2.000 - 2.200
1621	2.400 - 2.600
1621	2.800 - 3.000



Die No. 16026

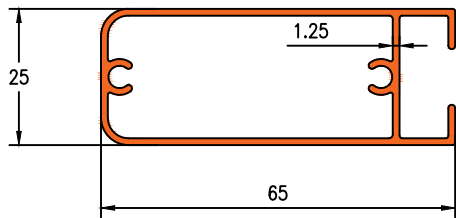

Die No. 1340

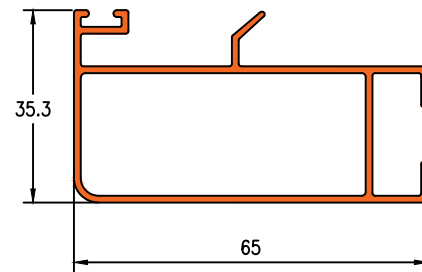

Die No. 1340M

2.450 Kg/12FT

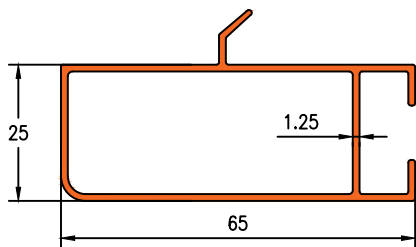

Die No. 1339

2.870Kg/12FT

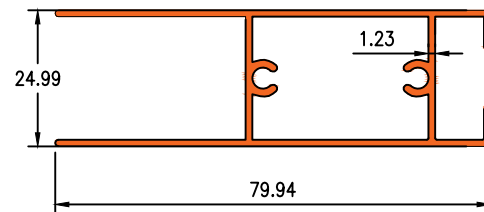

Die No. 1341

2.570 Kg/12FT

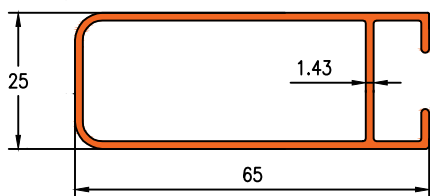

Die No. 16165

2.780 Kg/12FT

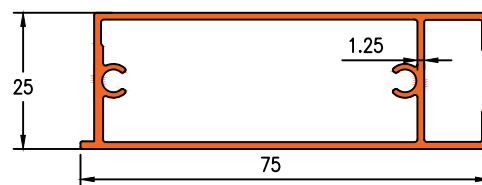

Die No. 16166

2.940 Kg/12FT

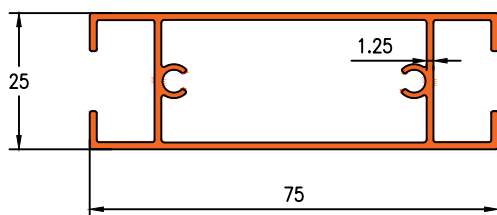

Die No. 10059

2.490 kg/12FT

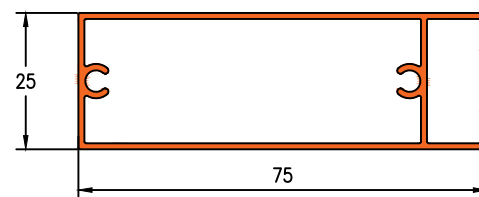



Die No. 16229

1.860 Kg/12FT

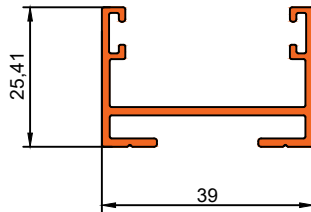

Die No. 16230

1.860 Kg/12FT

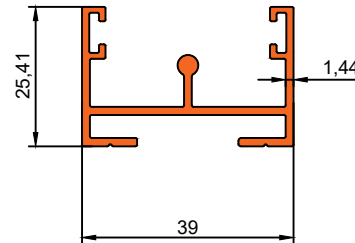

Die No. 1151

2.090 Kg/12FT

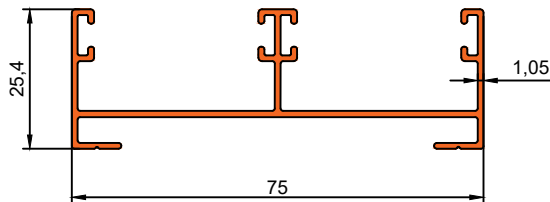

Die No. 1156

2.300 Kg/12FT

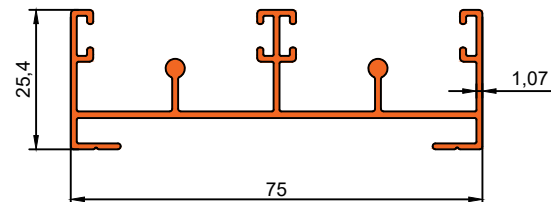

Die No. 1161

3.000 Kg/12FT
3.340 kg/12FT

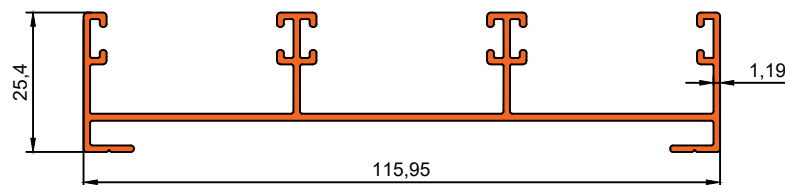

Die No. 1166

3.560 Kg/12FT
4.000 Kg/12FT

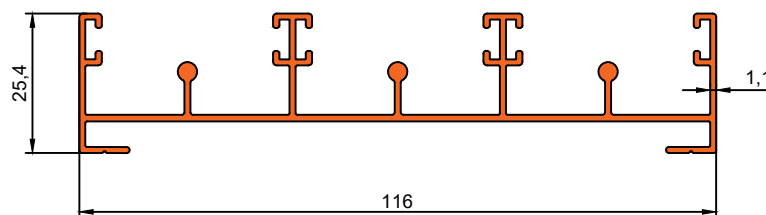



Die No. 16080

4.200 Kg/12FT

4.800 Kg/12FT

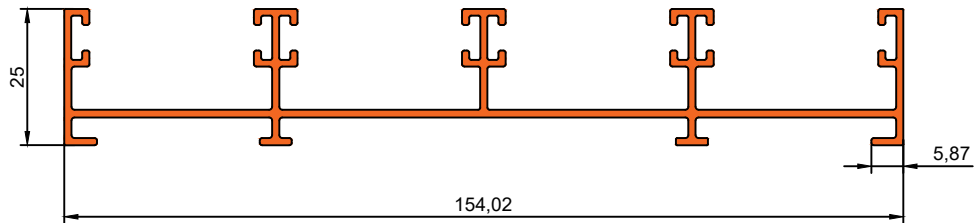

Die No. 16081

5.215 Kg/12FT

6.100 Kg/12FT

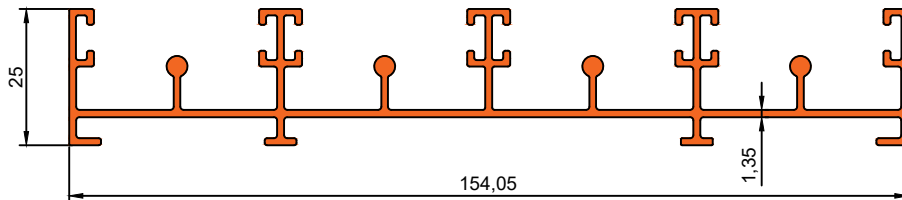

Die No. 16146

6.200 Kg/12FT

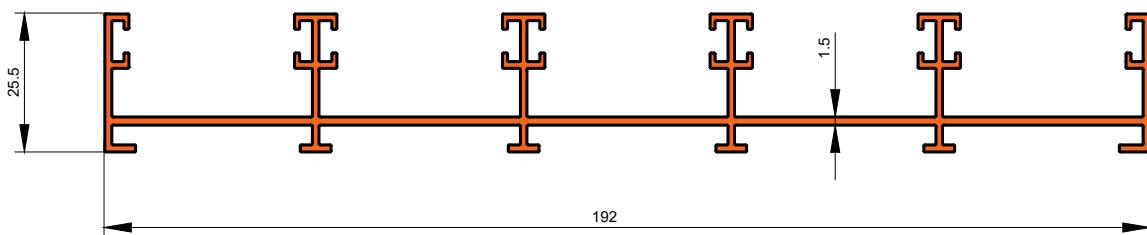

Die No. 16147

7.300 Kg/12FT

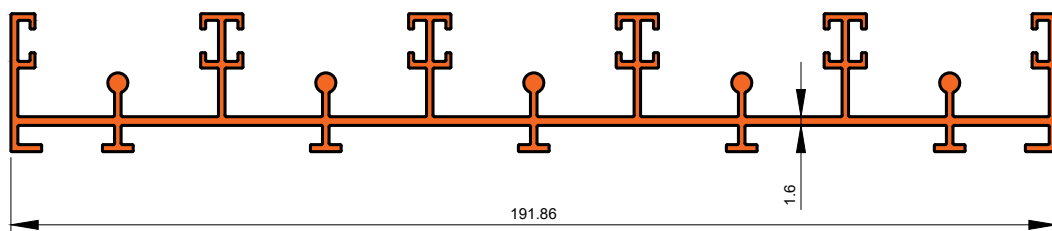



Die No. 19459

3.870 Kg/12FT

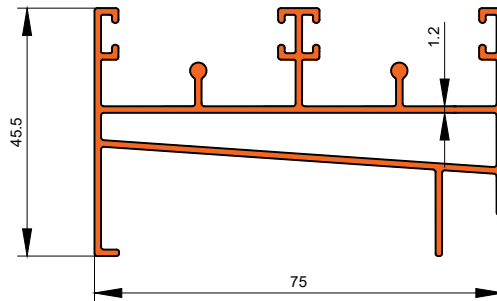

Die No. 19426

5.930 Kg/12FT

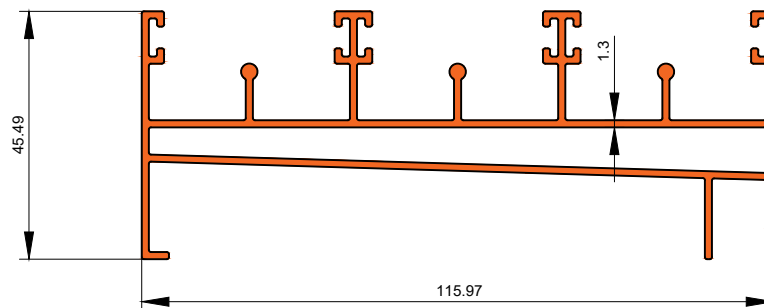

Die No. 19820

5.280 Kg/12FT

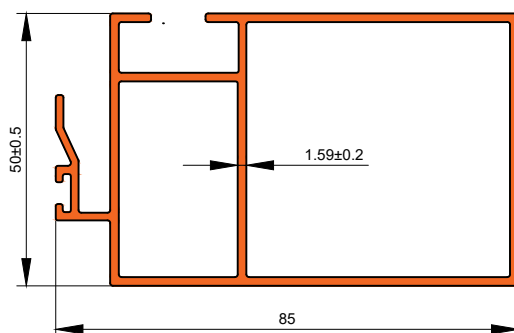



Die No. 19454

0.722Kg/m

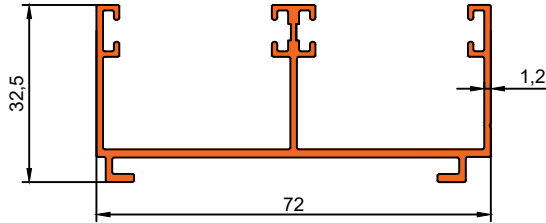

Die No. 19391

0.981Kg/m

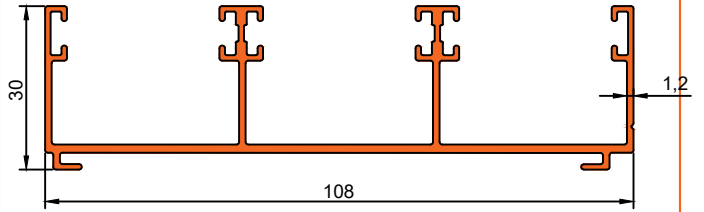

Die No. 19453

1.343Kg/m

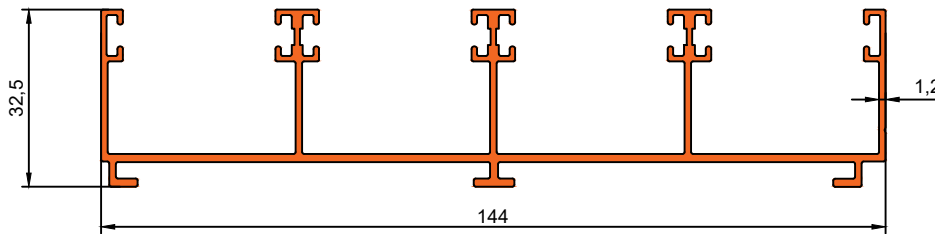

Die No. 19386

0.567Kg/m

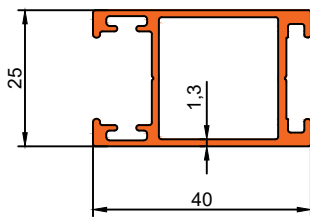

Die No. 19387

0.575Kg/m

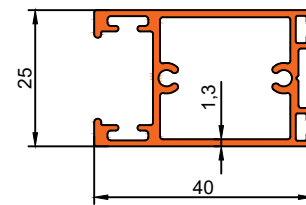

Die No. 19388

0.729Kg/m

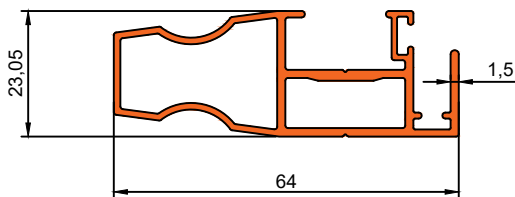

Die No. 19389

0.502Kg/m

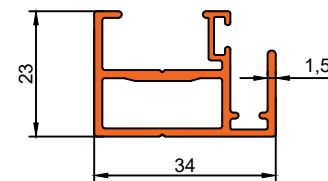



Die No. 19836

0.578Kg/m

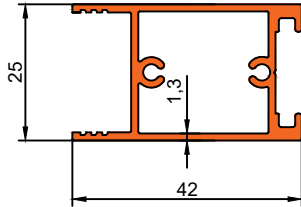

Die No. 19835

0.512Kg/m

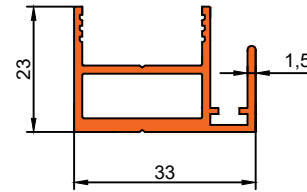

Die No. 19390

0.286Kg/m

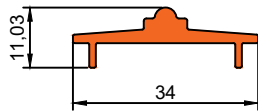



Die No.19920

0.624Kg/m

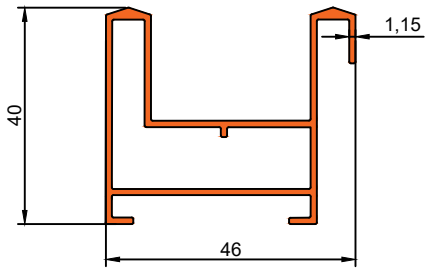

Die No.19677

0.814Kg/m

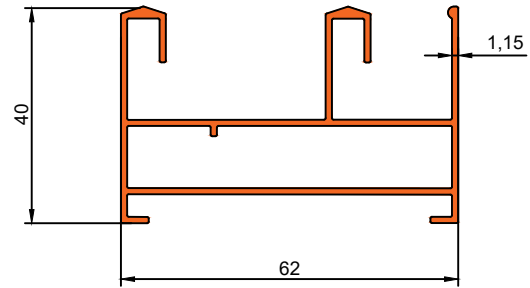

Die No.19656

0.908Kg/m

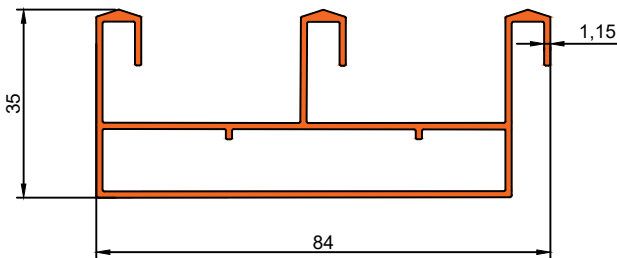

Die No.19917

0.965Kg/m

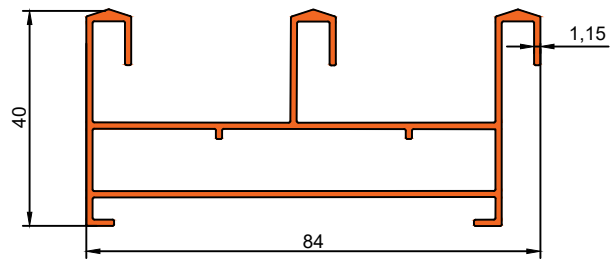

Die No.19951

1.064Kg/m

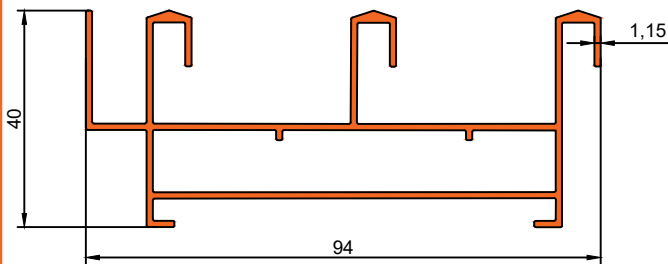

Die No.19678

1.176Kg/m

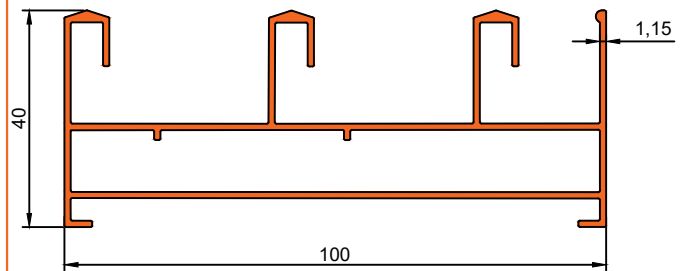

Die No.19650

1.324Kg/m

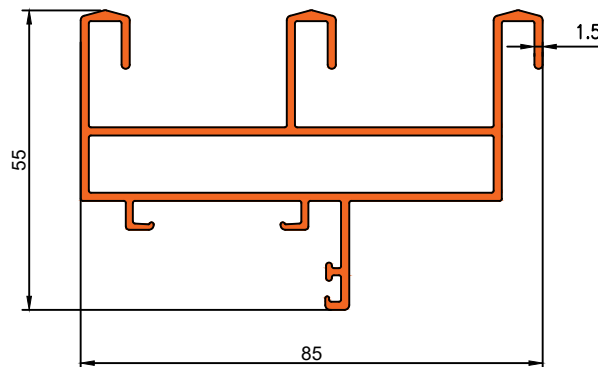



Die No. 16422

0.997 Kg/m

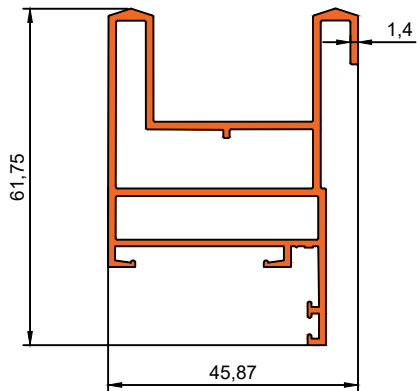

Die No. 16423

0.566 Kg/m

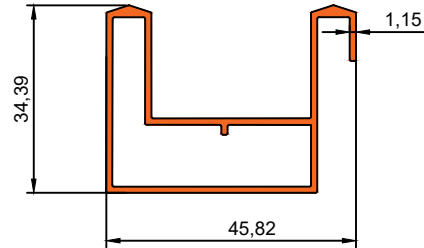

Die No. 16424

0.454 Kg/m

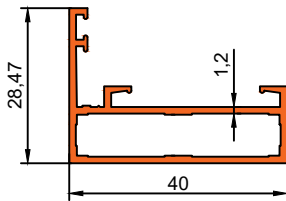

Die No. 19916

0.647 Kg/m

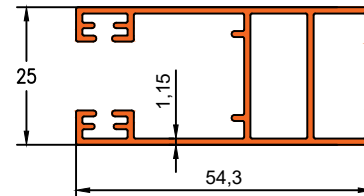

Die No. 19475

0.661 Kg/m

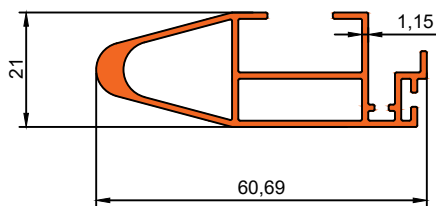

Die No. 19913

0.402 Kg/m

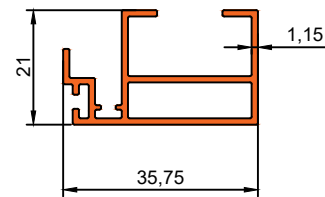

Die No. 19950

0.601 Kg/m

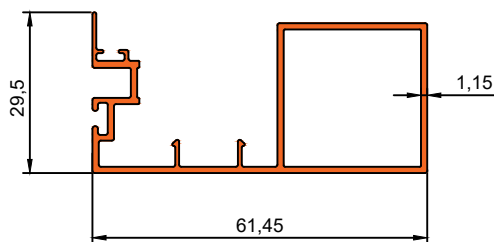

Die No. 19662

0.251 Kg/m

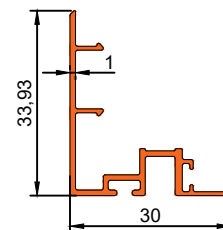



Die No. S7011

0.927Kg/m

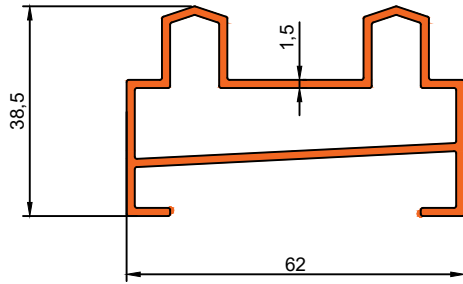

Die No. S7013

1.224Kg/m

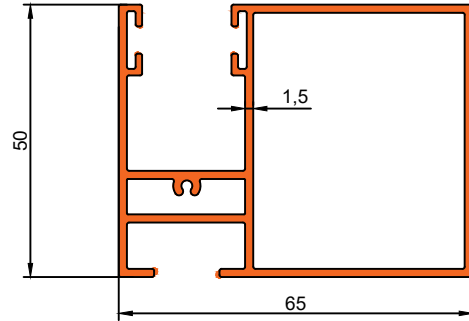

Die No. S7014

0.613Kg/m

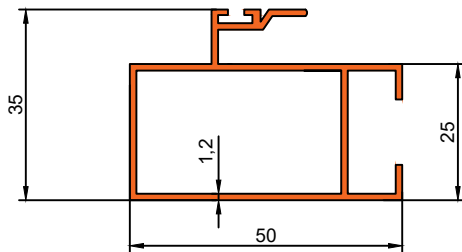

Die No. S7012

1.365Kg/m

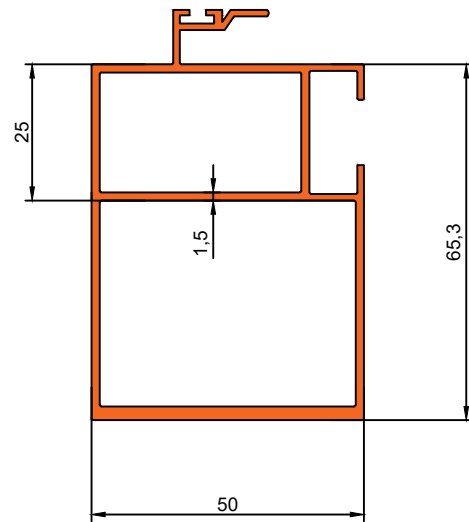

Die No. S7015

0.744Kg/m

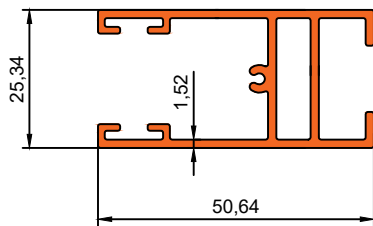



Die No. 19518

2.235Kg/m

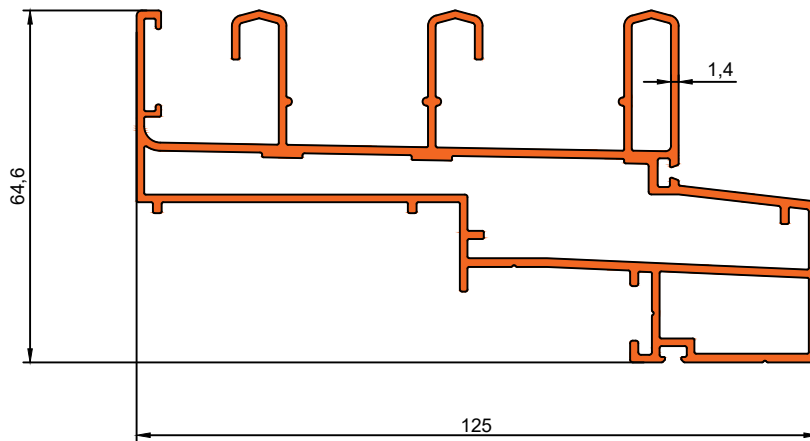

Die No. 19519

1.792Kg/m

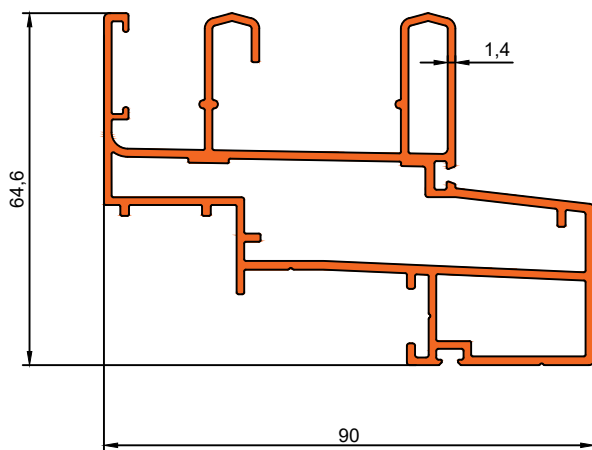

Die No. 19520

0.971Kg/m

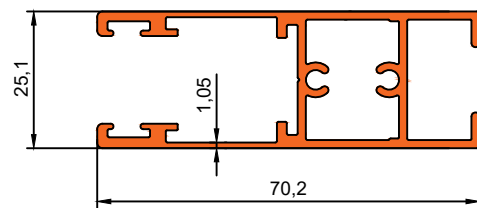

Die No. 19913

0.402Kg/m

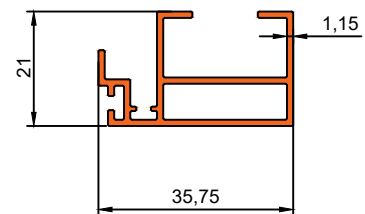



Darshan Extrusions Pvt. Ltd.

Die No. 1343

0.970Kg/m

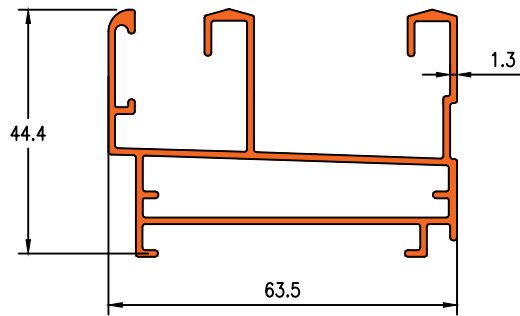

Die No. 21041

0.879 kg/mtr

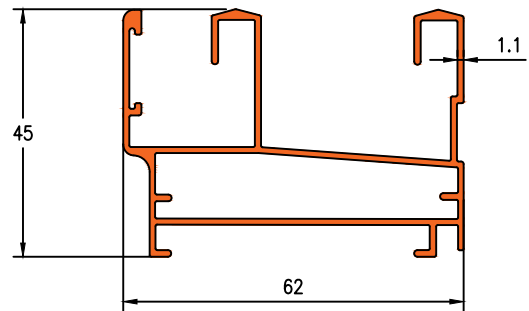

Die No. 1332

1.444Kg/m

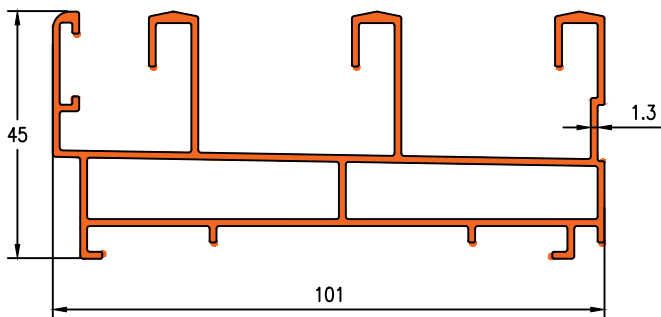

Die No. 21042

1.303 kg/mtr

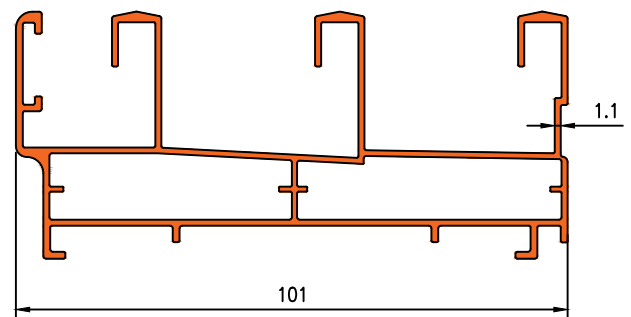

Die No. 28193

1.835Kg/m

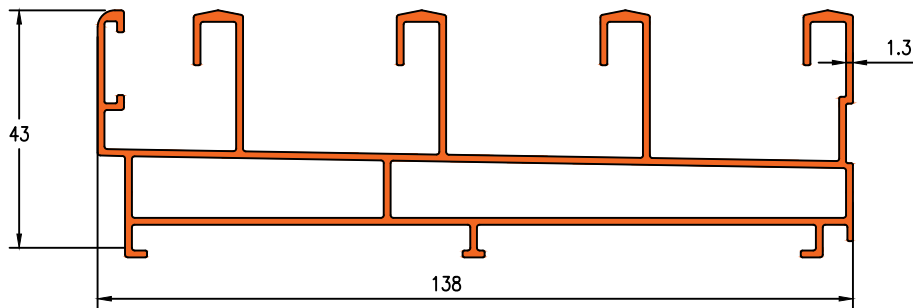

Die No. 1333

0.690Kg/m

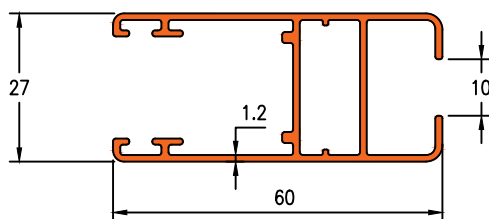

CLIP : 1331

Die No. 16180

0.675Kg/m

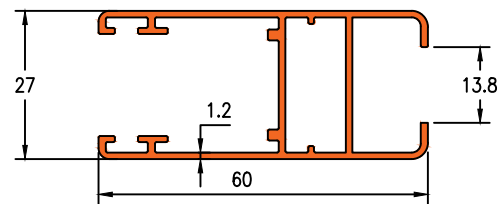

CLIP : 1331



Die No. 19735

0.644Kg/m

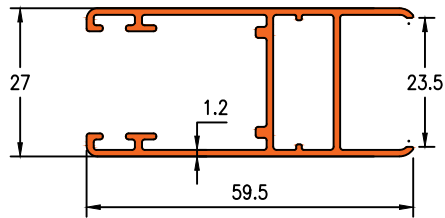

Die No. 1331

0.322Kg/m

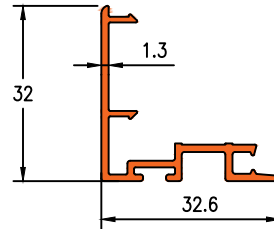

Die No. 20028

0.549Kg/m

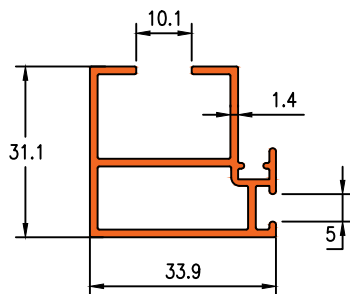

Die No. 20029

0.499Kg/m

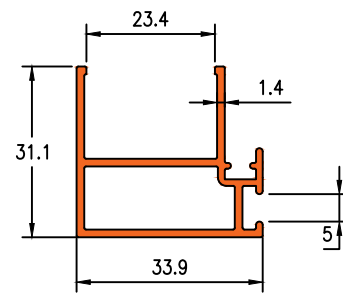

Die No. 20065

1.204Kg/m

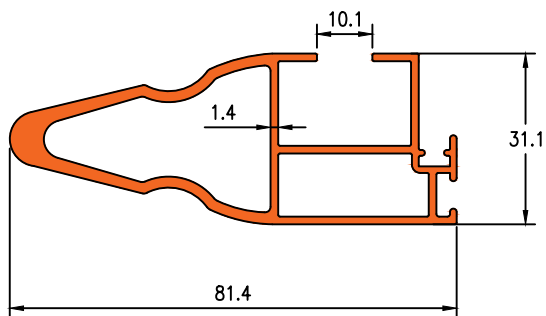

Enq No.900

1.154 Kg/m

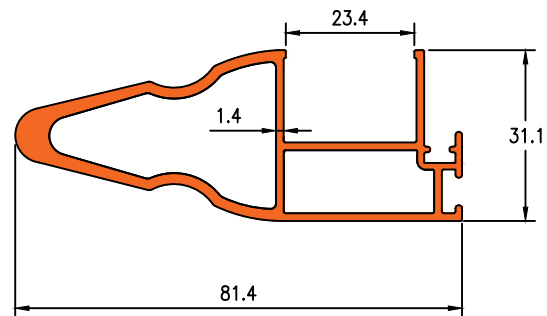

Die No. 19376

0.680Kg/m

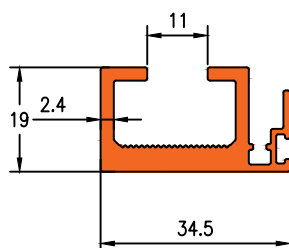

Die No. 19332

1.394 Kg/m

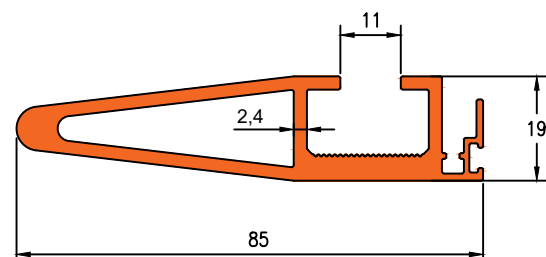



Die No. 21074

1.029 Kg/m

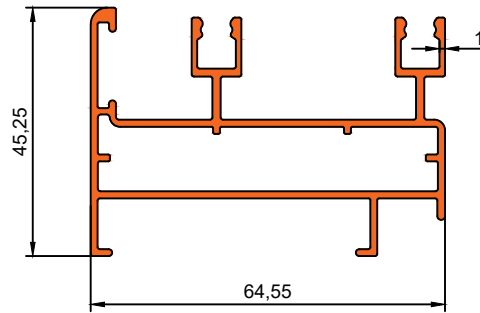

Die No. 21059

1.409 Kg/m

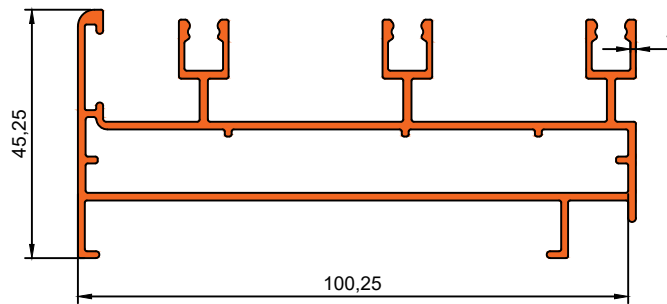



Die No. 2701

0.719Kg/m

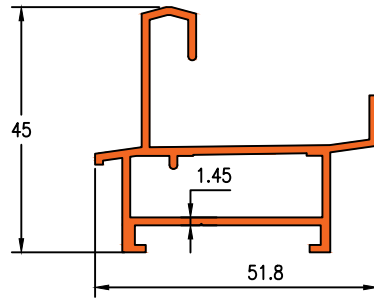

Die No. 2702

0.871Kg/m

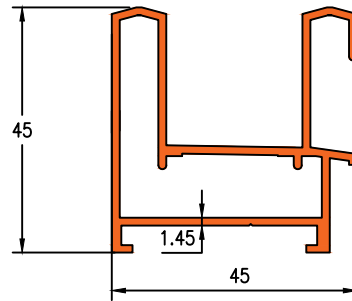

Die No. 2703

1.398Kg/m

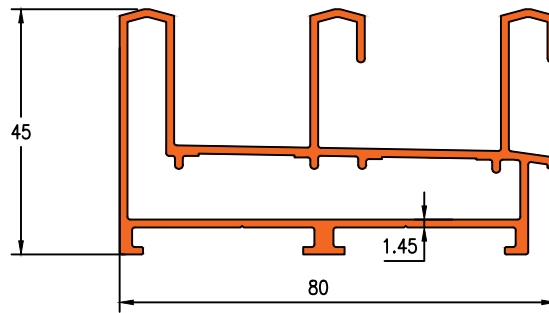

Die No. 2704

1.905Kg/m

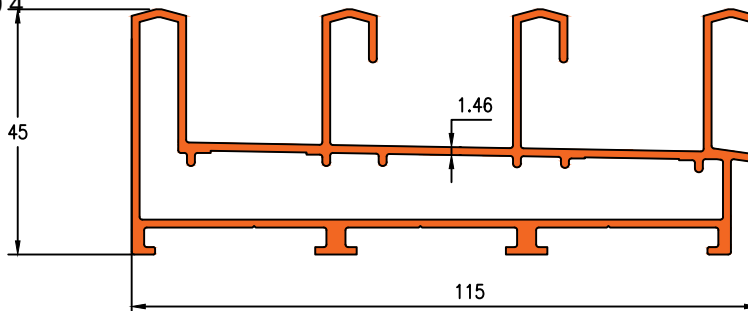



Die No. 2708

0.862Kg/m

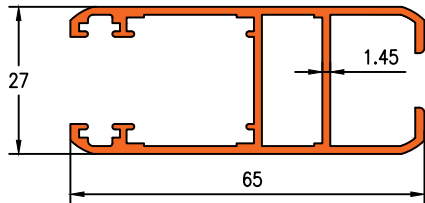

CLIP :2709 & 16141

Die No. 2707

0.890Kg/m

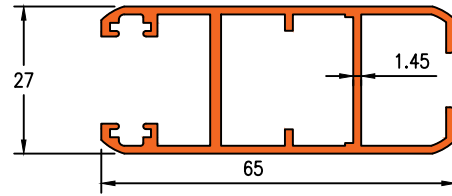

CLIP :2709 & 16141

Die No. 2705

0.810 Kg/m

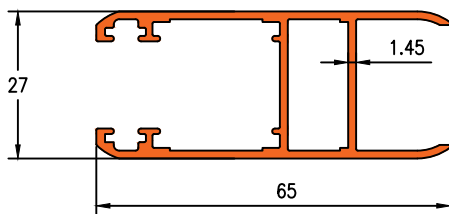

CLIP :2709 & 16141

Die No. 2706

0.838Kg/m

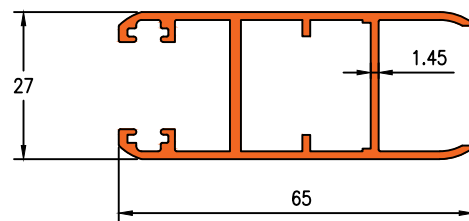

CLIP :2709 & 16141

Die No. 2709

0.273Kg/m

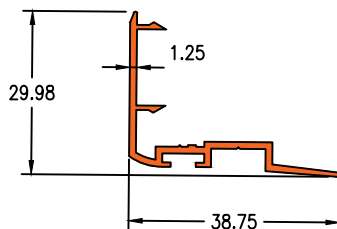

Die No. 2710

0.262Kg/m

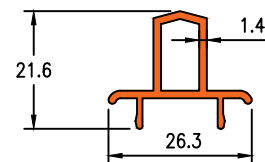



Die No. 1211

0.693Kg/m

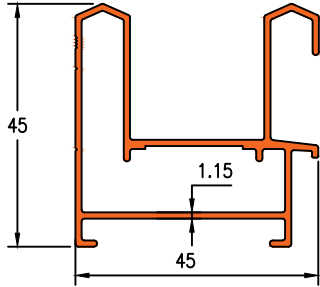

Die No. 1210

1.081Kg/m

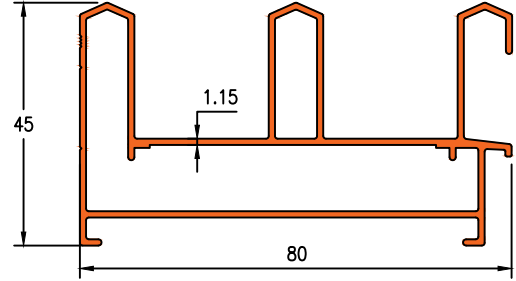

Die No. 1212

0.755Kg/m
0.855Kg/m

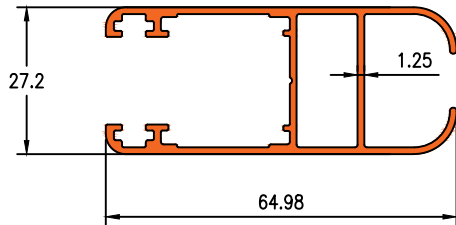

CLIP : 1213

Die No. 1213

0.260Kg/m

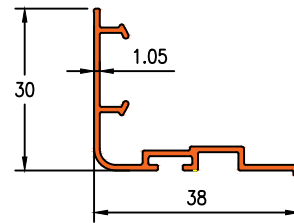

Die No. 16177

1.262Kg/m

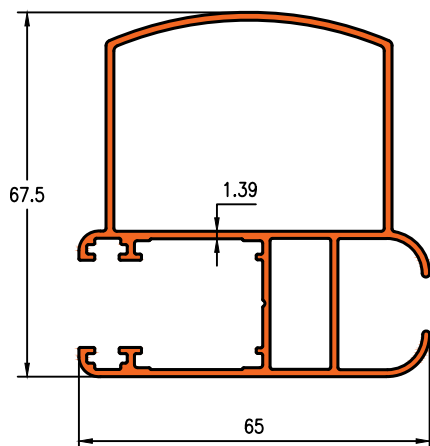

CLIP : 1213

Die No. 28197

0.681Kg/m

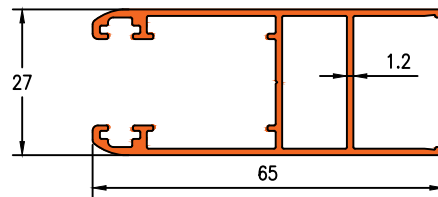

Die No. 28192

0.272Kg/m

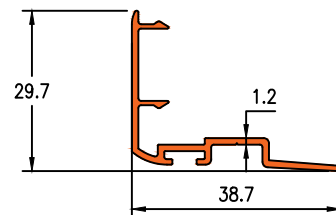



Die No. 16197

1.108Kg/m

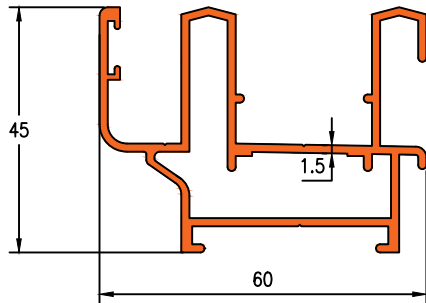

Die No. 16195

1.712Kg/m

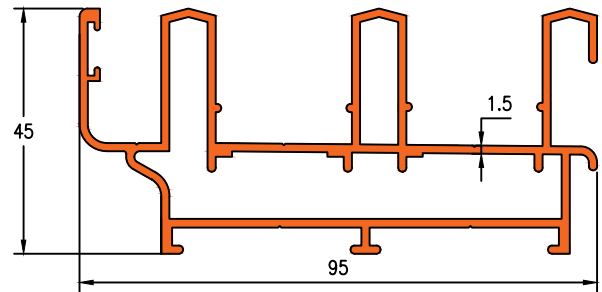

Die No. 19474

1.107Kg/m

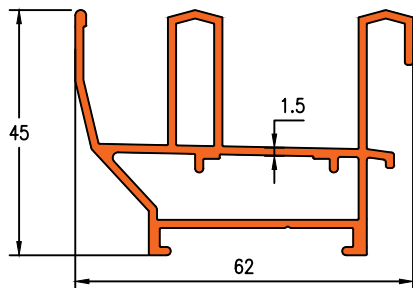

Die No. 16199

0.247Kg/m

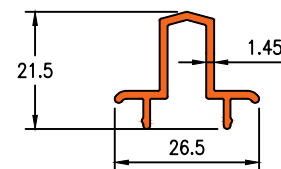

Die No. 16200

0.860Kg/m

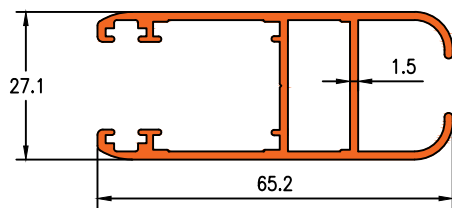

Die No. 16198

0.829Kg/m

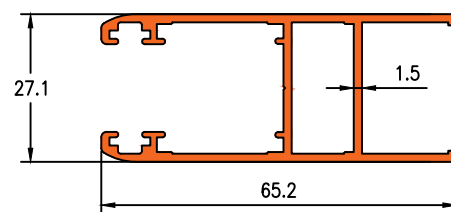

Die No. 16209

1.180Kg/m

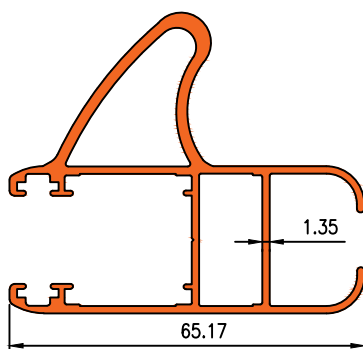

Die No. 16196

0.272Kg/m

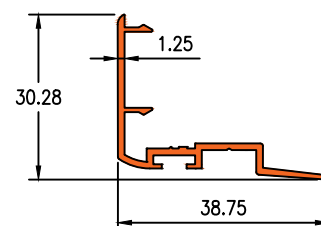



Die No. 19625

1.865 Kg/m

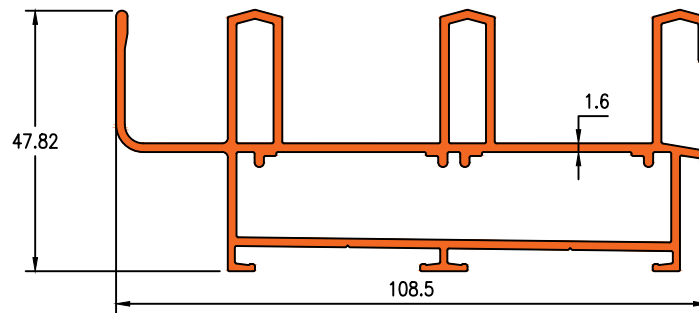

Die No. 19626

1.185 kg/mtr

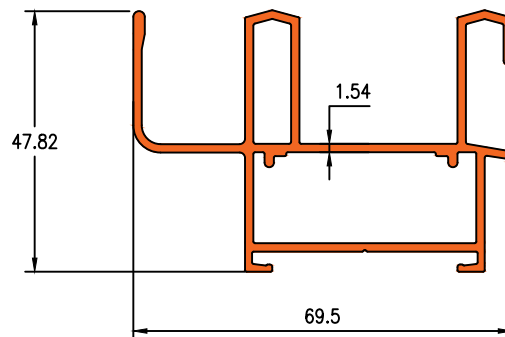

Die No. 19620

0.779 Kg/m

Die No. 19623

1.082 Kg/m

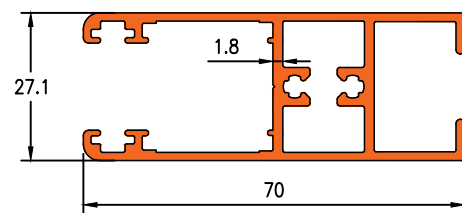
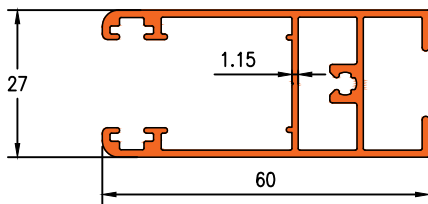

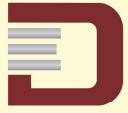

Die No. 16105

1.856Kg/m

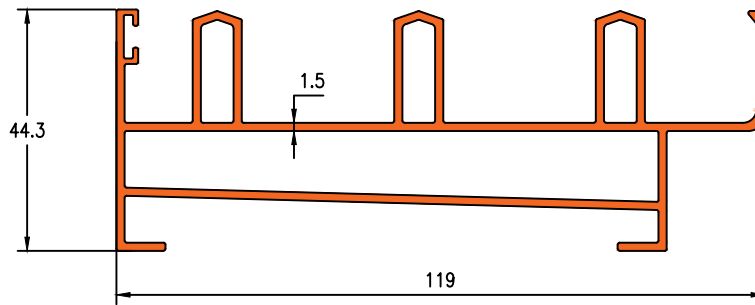

Die No. 16106

0.970Kg/m

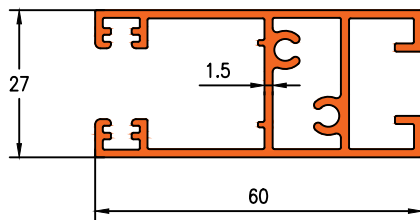

Die No. 16108

0.612Kg/m

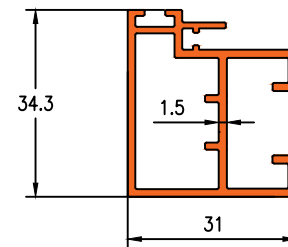

Die No. 16107

1.347Kg/m

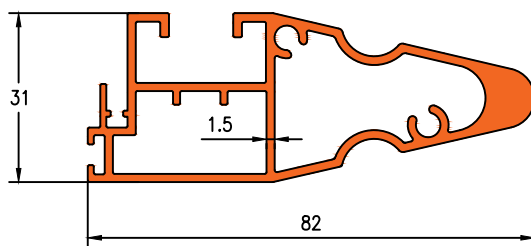



Die No. 16138

0.629Kg/m

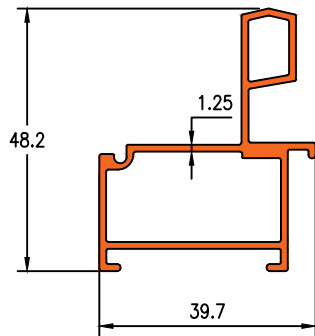

Die No. 16137

1.112Kg/m

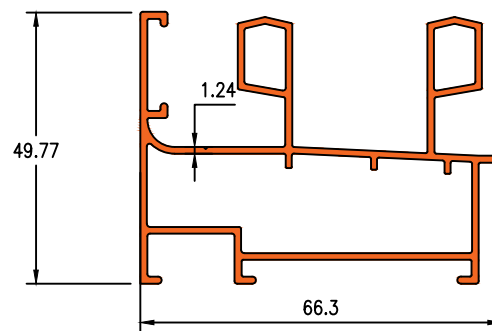

Die No. 16136

1.584 Kg/m

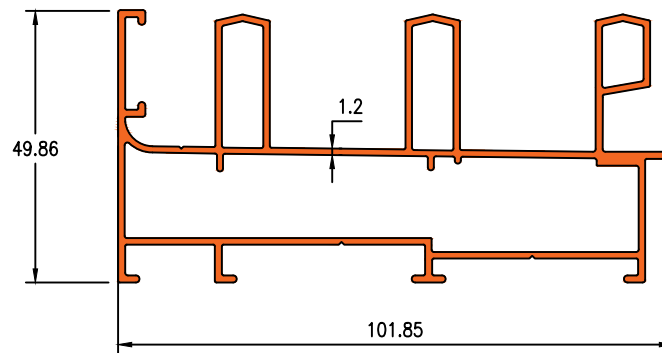

Die No. 16135

2.225Kg/m

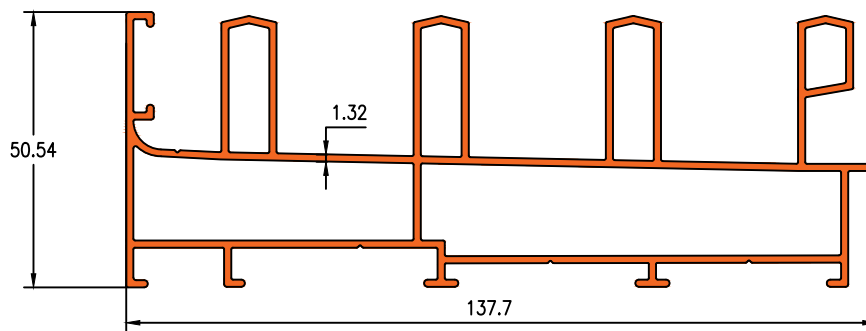

Die No.19537

3.091Kg/m

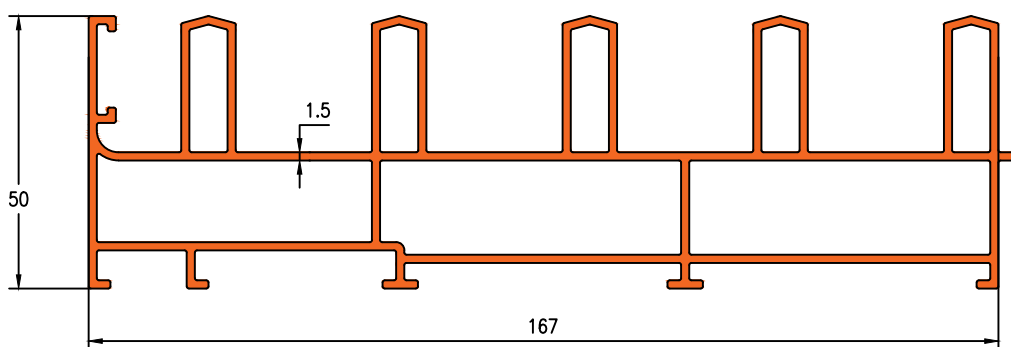



Die No. 16140

0.744Kg/m

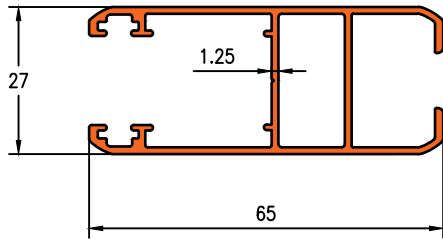

Die No. 16139

0.723Kg/m

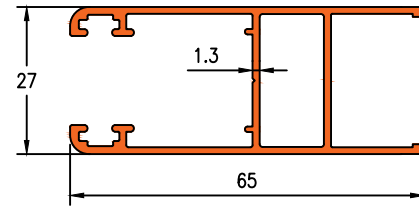

Die No. 19722

0.699Kg/m

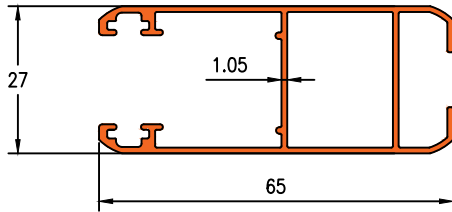

Die No. 21019

0.794Kg/m

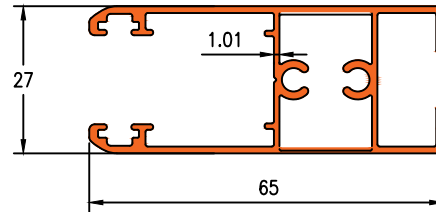

Die No. 16141

0.273Kg/m

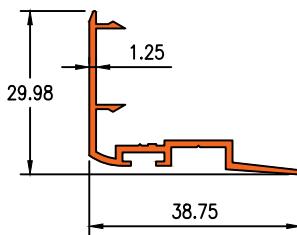

Die No. 19469

0.177Kg/m

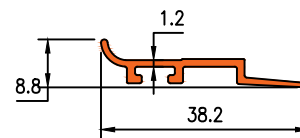

Die No. 19478

0.748Kg/m

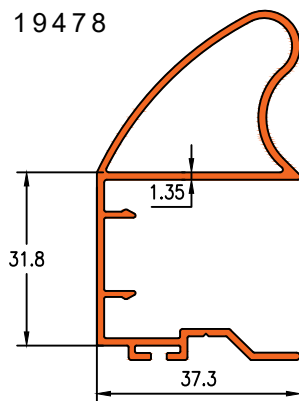

Die No. 20017

0.117Kg/m

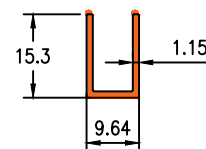



Die No. 20028

0.549Kg/m

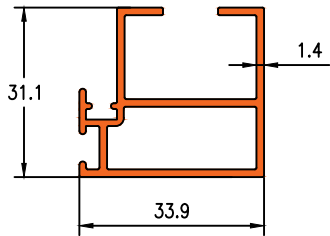

Die No. 20029

0.499Kg/m

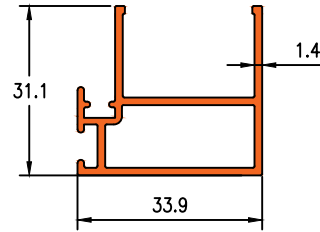

Die No. 19376

0.680Kg/m

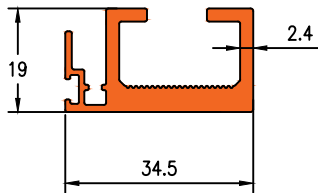

Die No. 19332

1.394Kg/m

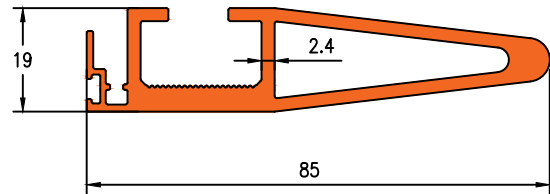

Die No. 21018

0.549Kg/m

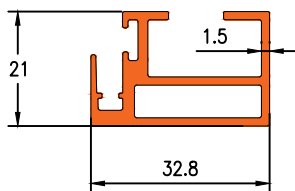



Die No. 30005

0.718 Kg/m

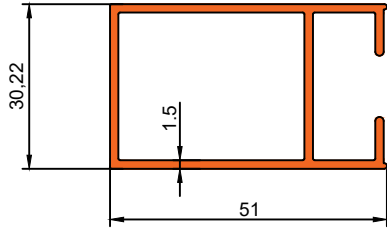

Die No. 30006

0.834 Kg/m

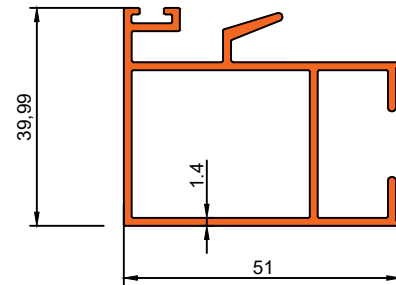

Die No. 30007

0.709 Kg/m

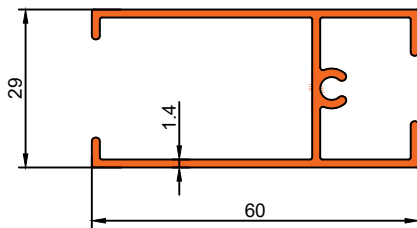

Die No. 30001

0.819 Kg/m

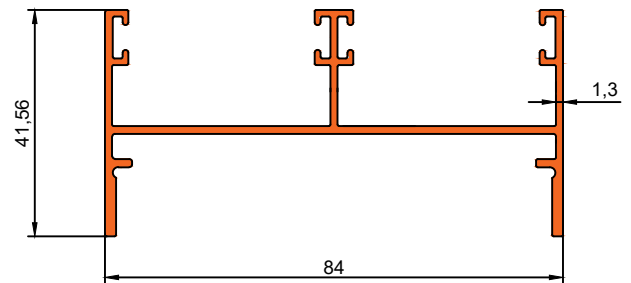

Die No. 30002

1.33 Kg/m

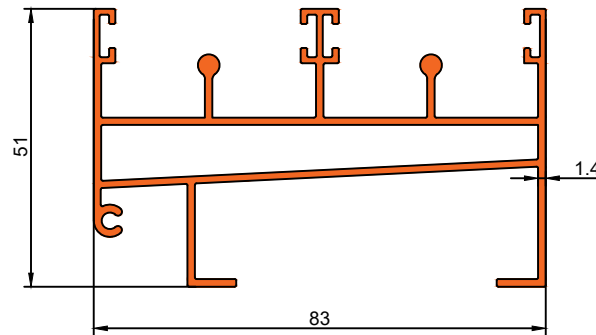

Die No. 30003

1.085 Kg/m

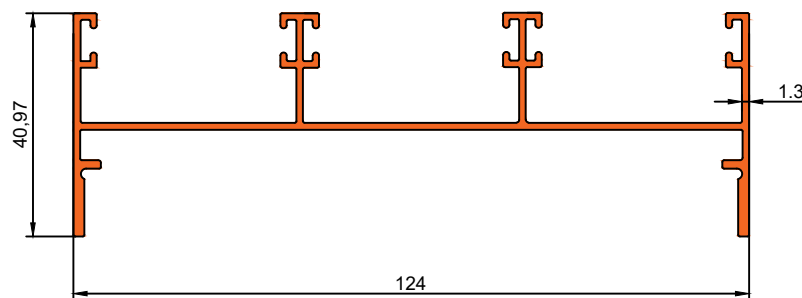

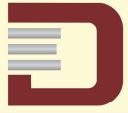

Die No. 30004

1.819Kg/m

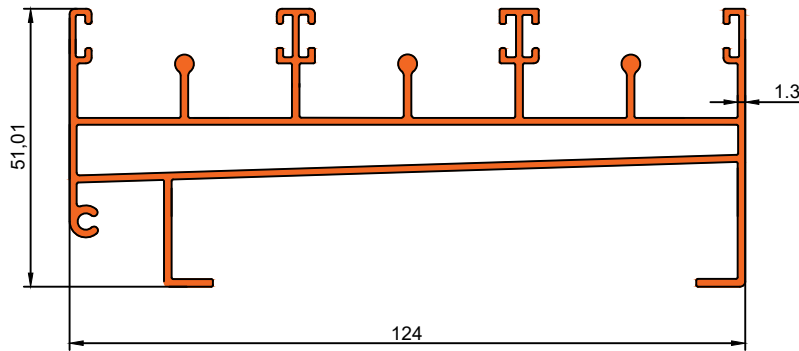

Die No. 16245

1.759Kg/m

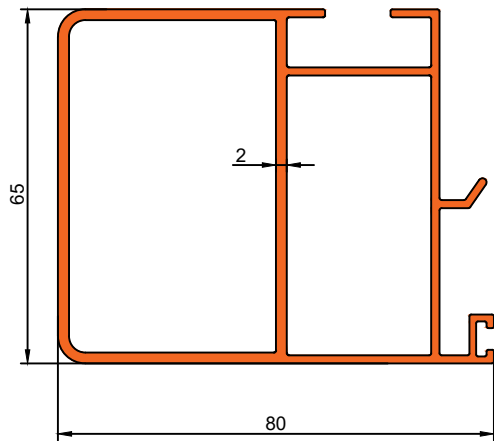



Die No. 16066

1.450Kg/m

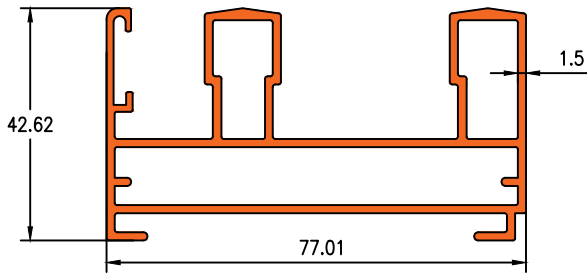

Die No. 19452

1.827Kg/m

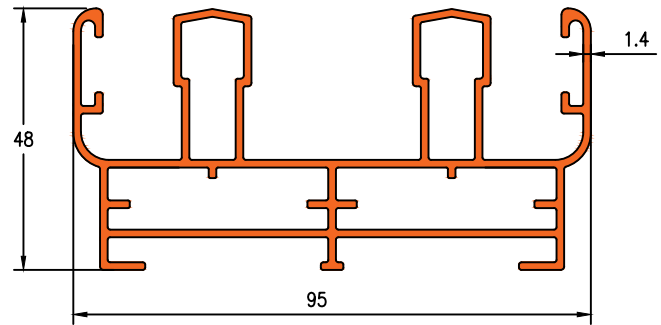

Die No. 19640

2.137 Kg/m

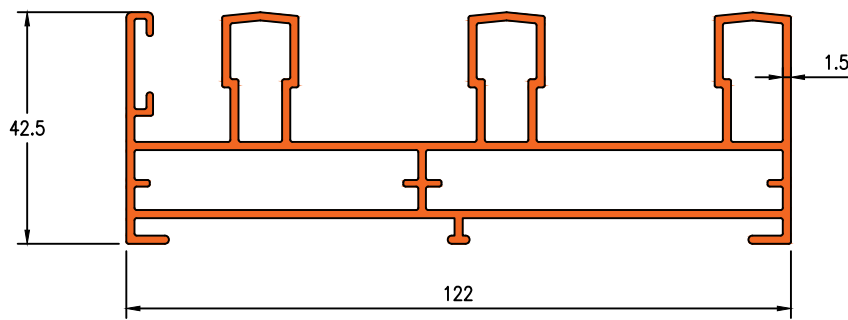

Die No. 16192

2.365Kg/m

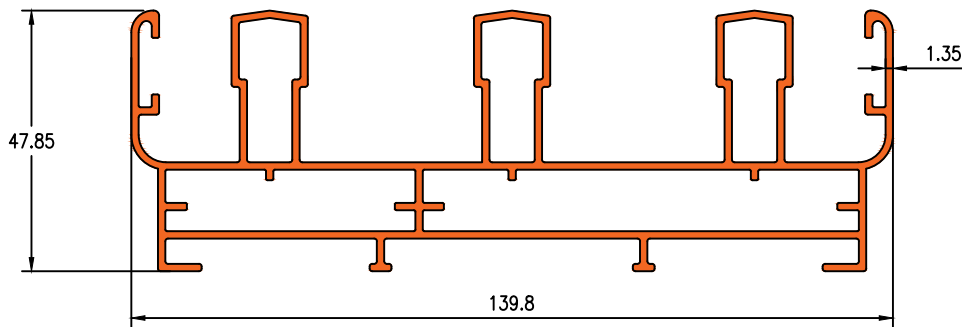

Die No. 19443

0.988Kg/m

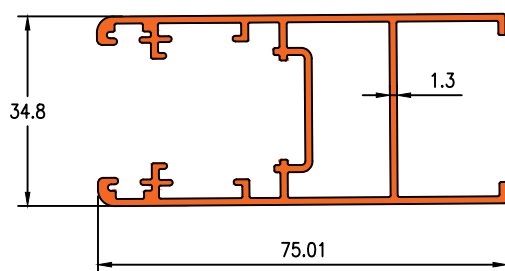

Die No. 16193

1.035Kg/m

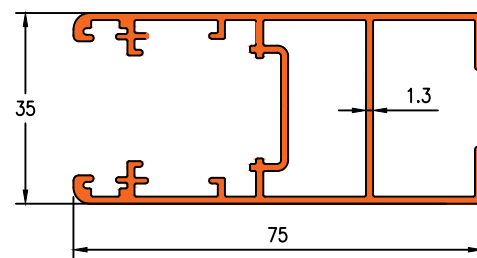



Die No.20026

0.684Kg/m

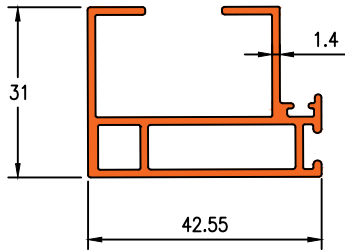

Die No.20027

0.633Kg/m

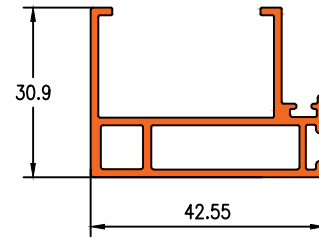

Die No.20066

1.321Kg/m

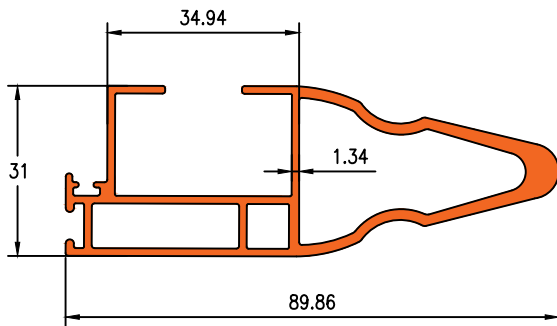

Die No. 16194

0.380Kg/m

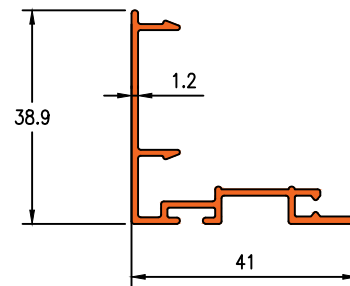

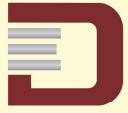

Die No. 21047

1.309Kg/m

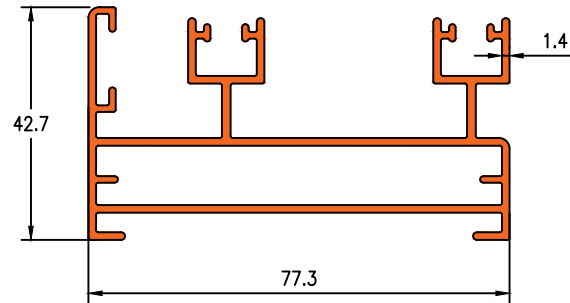

Die No. 21048

1.909Kg/m

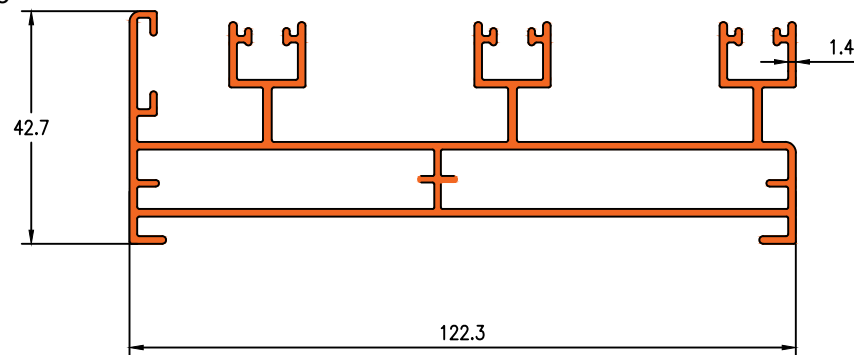

Die No. 16193

1.037Kg/m

Die No. 19443

0.988Kg/m

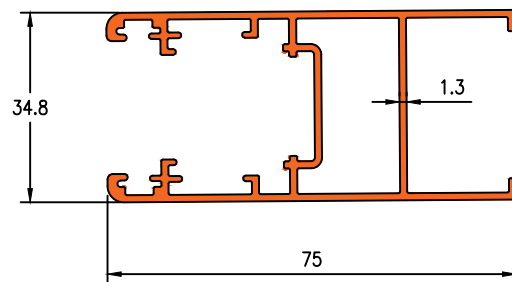
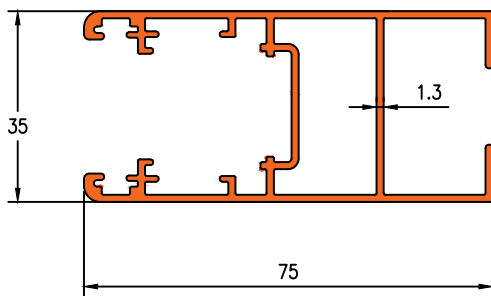

Die No. 16194

0.380Kg/m

